

The meeting was called to order at 8 p.m. and began with the Pledge of Allegiance.

David Taylor, Bill Norris, Dennis Sazama, Echo Dockter and Karen Marthaler were present.

See the sign in page, attached, for a list of other people attending the meeting.

The agenda was reviewed and additions were made. These include: a report from Jeff Stabnow under Road Report, a request for gravel for a minimum maintenance road, correspondence from the Little McDonald and Kerbs Lake Association Board, a request from Fred Bauck added to Road Report and an email from Darrel Nordick. Dennis requested the addition of a discussion of supervisors jobs under New Business and a discussion of weed control under Road Report. David added a discussion of the resolution regarding Board Compensation. A motion was made, seconded and passed unanimously to add these items to the agenda.

The clerk's report was passed out. A motion was made, seconded and passed unanimously to accept it as presented. David also requested that the proposed minutes be emailed to the supervisors before the meeting.

The Treasurer's Report showed receipts of \$242,358.73, disbursements of 20,331.92 and a balance of \$468,220.04. A motion was made, seconded and passed unanimously to accept the report as presented.

The claims for payment were presented. The list is attached. A motion was made, seconded and passed unanimously to pay the claims.

There were no bounties presented.

The road report began with a discussion of the 5 tons signs. The decision to post 5 ton signs came from the discussion of the damage to the roads done this Spring. Bill read the letter from the Little McDonald-Kerbs Lake Association requesting that the township road restrictions not be more restrictive than the Otter Tail County restrictions. Bill suggested that it would be possible to change this with another motion. The discussion following covered several points:

- a) The 5 ton limit refers to 5 tons per axle.
- b) County roads are built to be 10 ton per axle roads. Township roads are not built to the same standards.
- c) Spring weight restrictions declared at the county level do affect township roads.
- d) Are garbage trucks and school buses exempt?

Bill made a motion to bring the issue of 5 ton road signs to the annual meeting in March. There was no second to the motion. More discussion followed including questions of commerce versus convenience, ease of doing business, and enforcement. One of the major talking points was that without signs there is no recourse. It was also mentioned that Dead Lake Township does have 5 ton signs. Edna Township would not be the only one to have posted restrictions.

After this discussion Dennis seconded the motion to bring the issue of the 5 ton road signs to the Annual meeting. Bill and Dennis voted in favor, David opposed.

Bill made a motion to run gravel on all minimum maintenance roads in the township. There was no second. There was discussion of the condition of the Purlieu road in particular. Dennis made a motion to have David inspect all the minimum maintenance roads to see which ones, and which spots needed gravel and to bring a list and quotes to the August meeting. Bill seconded the motion and it passed unanimously. David was directed to inspect the Purlieu road as soon as possible and act if it required immediate attention.

Fred Bauck's letter was read, requesting gravel to fix equalizing the flow out of the ditch into the culvert near his home. A motion made, seconded and passed unanimously to look at this and fix immediately if it is an emergency.

The next item concerns weed control. There are noxious weeds all over Edna Township, including spotted nap weed and thistles. These weeds have to be plowed under, cut or sprayed. It was suggested that land owners be contacted and asked to take care of the weeds, making the assumption that many people do not realize they are required to do this. Dennis, who is the Weed Inspector for the township will undertake this task and report at the August meeting.

Questions from the audience included whether trees on 400th street in the right-of-way will be removed. The trees that are in questions are 4"-5" in diameter. They are scheduled to be taken care of with the brushing that will be done this Fall. It was also mentioned that there are trees on Spur road that are blocking the signs. These are also included in the brushing this Fall.

Edna Township
July Meeting 7-21-15

Dan Merrill

ALLAN DAMMANN

Bill Putnam

Bob & Sue Heyhuber

Kim Danitt

David Johnson

Roger A. Nitzke

Jeff Stabnow

Ken. Uehring

Jim Nigg

Ilkni Angleson

Maryann Anderson

Terri Marshall

Andell Wejand

Doug Colding

~~John~~
Paul Christensen



David Wenzel

Arnold Coetzer

Date Range : 7/19/2015 To 7/19/2015

<u>Date</u>	<u>Vendor</u>	<u>Description</u>	<u>Claim #</u>	<u>Total</u>	<u>Account #</u>	<u>Account Name</u>	<u>Detail</u>
07/19/2015	Svingen, Cline & Larson, P.A.	Dennis' request regarding road vacation	2782	\$294.00	100-41601-304-	Legal Services	\$294.00
07/19/2015	Echo Dockter	Reimbursement for stamp for the required check endorsement	2783	\$35.60	100-41110-200-	Council/Town Board	\$35.60
07/19/2015	Arntson Construction LLC	Crack Sealing	2784	\$10,540.00	201-43101-220-	Highways, Streets & Roadways	\$10,540.00
07/19/2015	Dead Lake Township	1/2 cost of gravel and work on 400th St (town line road)	2785	\$629.50	201-43101-224-	Highways, Streets & Roadways	\$629.50
07/19/2015	Dunn Transfer Inc	Hauling 6 pallets of crack seal	2786	\$300.00	201-43101-220-	Highways, Streets & Roadways	\$300.00
07/19/2015	Stenger's Dust Control	Applied dust control @.875/gal	2787	\$8,093.75	201-43122-224-412	Unpaved Streets	\$8,093.75
07/19/2015	Sonnenberg Excavating	Mowing road ditches	2788	\$1,508.00	201-43101-400-404	Highways, Streets & Roadways	\$1,508.00
07/19/2015	Sonnenberg Excavating	Hauling gravel for Kerbs Lake Rd	2789	\$10,383.75	201-43101-400-403	Highways, Streets & Roadways	\$10,383.75
07/19/2015	Sonnenberg Road Maintenance, LLC	Road Grading 6/1 through 6/30	2790	\$3,410.00	201-43122-224-402	Unpaved Streets	\$3,410.00
Total For Selected Claims				\$35,194.60			\$35,194.60

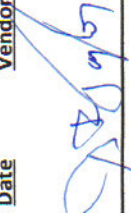
Date Range : 7/19/2015 To 7/19/2015

<u>Date</u>	<u>Vendor</u>	<u>Description</u>	<u>Claim #</u>	<u>Total</u>	<u>Account #</u>	<u>Account Name</u>	<u>Detail</u>
							
	David Taylor	Town Supervisor					7-21-15
							
	Dennis Sazama	Town Supervisor					7-21-15
							
	William Norris	Town Supervisor					7-21-15

For the payroll period ending:

<u>Employee Name</u>	<u>Employee Number</u>	<u>Account Number</u>	<u>Allocation Amount</u>	<u>Check Number</u>
Dockter, Echo L		100-41425-100	\$467.75	
		Net Pay:	\$467.75	
Marthaler, Karen		100-41510-100	\$374.20	
		Net Pay:	\$374.20	

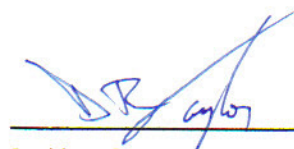

David Taylor

Town Supervisor

7-21-15

Date

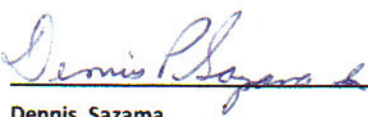

Dennis Sazama

Town Supervisor

7-21-15

Date



William Norris

Town Supervisor

7-21-15

Date

SVINGEN, CLINE LARSON, P.A.
ATTORNEYS & COUNSELORS AT LAW

Attorneys:

R. Kristian Svingen ◊▲

J. J. Cline ◊▲

Greg Larson

Thomas C. Athens

Matthew Jorud

Telephone: 218-998-4088

Facsimile: 218-998-4087

Toll Free: 888-498-5599

July 6, 2015

Edna Township Board
c/o Dennis Sazama, Supervisor
43069 Co. Hwy. 35
Dent, MN 56528

Dennis asked me if I would write and clarify the Township's administration of its roads.

I see from the minutes of your regular March meeting that Dave Taylor has been appointed as Road Authority. It is important to keep in mind that only he should be dealing with road problems and making recommendations to the full Board concerning any actions to be taken. All actions concerning roads in the Township must be made pursuant to motion or resolution at a regular or special meeting. There are certain emergency situations which may arise where the road authority must act immediately but such actions should be approved at the next meeting.

Finally, since Dave is the current Road Authority, only he should be dealing with those problems prior to making recommendation to the full Board. I know that people contact the other Board members with concerns and want immediate action, but when that happens, Dave should be contacted and deal with the situation and make the appropriate recommendation to the full Board.

If you have any questions, please advise.

Very truly yours,



R. Kristian Svingen

km

125 South Mill Street, Fergus Falls, MN 56537
www.svingenlaw.com

Offices in Fergus Falls, Pelican Rapids and Battle Lake
Weekly Office Hours in Vergas, Dalton and Underwood

◊Also admitted to practice in ND ▲Qualified ADR Neutral

RE: Application for Access Approach Permit

In response to your request, we are enclosing an "Application for Access Approach Permit", which you must complete.

On the back side of the application, please sketch your property and the present and proposed approaches. Please be neat and complete showing distances, as close as possible, from land corners, intersections of highways, etc.

Please mark the exact location on the ground with a lath and attach flag where you want the proposed approach so it will be easy to locate.

The landowner will be required to submit a permit processing fee in the amount of \$100 with the permit application. The application must also be accompanied by a separate \$500 assurance deposit in the form of a cashier's check, money order, or other bank draft made payable to Edna Township.

Fee is waived if permit is submitted by a licensed contractor. Licensed & bonded
The Supervisors will then investigate the location within ten (10) business days of receipt of the application, and if found to be satisfactory; the permit will be granted. The requesting landowner will be required to pay for the required steel culvert. The land owner will be responsible for all backfilling, placing topsoil, and seeding of all raw slopes; and the placing of granular surfacing material at your own expense, upon approval from the township. *an insured bonded*

Secondary access approaches may be allowed within a reasonable distance from primary access approaches, based on each individual circumstance with regards for new building construction, handicap access and other reasonable situations.

The deposit will be for the assurance that the access approach will be installed and completed in conformance with the permit, sketches and other requirements. A one year time frame will be allowed for completion. The deposit will be refunded upon the completion of work to the satisfaction of the Township. Additional inspections will be deducted from the assurance deposit and the Township reserves the right to cause the uncompleted work to be preformed and the costs shall be charged to the landowner.

ACCESS APPROACH POLICY

I. SCOPE

This policy applies to access approaches abutting all Township roads under the jurisdiction of Edna Township.

II. GENERAL

One (1) access approach shall be granted to each parcel of abutting property upon submission and approval of a permit application. The final location of the access approach will be at the discretion of the Edna Township Supervisors or their representative with consideration given to traffic safety parameters, location of nearby intersections, prevailing traffic patterns, size and shape of the land tract and building locations.

The requesting landowner will be required to pay for the required steel culvert for a standard access approach width and required in slopes. Standard access approaches shall have finished widths as follows:

Field Approach	20 feet maximum / 16 feet minimum
Private Drive	24 feet maximum / 16 feet minimum
Business Approach	30 feet maximum / 24 feet minimum

The cost of constructing the access approach shall be the responsibility of the requesting landowner. Wider approaches may be allowed at the discretion of the Town Supervisors.

Secondary access approaches may be allowed within a reasonable distance of the primary access approach based on each individual circumstance with regards for new building construction, handicap access, and other reasonable situations. Field access approaches will be allowed for each separate parcel of land.

III. PERMIT

Prior to any work being performed on the access approach, a permit must be secured. **IN ORDER FOR THE PERMIT TO BE VALID, IT SHALL BE SIGNED BY THE REQUESTING LANDOWNER AND APPROVED BY AN AUTHORIZED REPRESENTATIVE OF THE EDNA TOWNSHIP BOARD.**

The permit application shall include pertinent information required on the form. Prior to issuance of the permit, sketches will be checked and a field inspection will be required.

Upon completion of the installation, entirely in conformance with the permit and policy, a "Certificate of Completion" must be sent to the Township Clerk, notifying that the work is ready for final inspection. The work shall be accomplished in a manner that will not be detrimental to the town road and that will safeguard the public.

IV. FEES

The requesting landowner shall be required to submit a non-fundable permit fee in the amount of \$100.00 with the application. This can be in the form of a personal check or cash. The application shall also be accompanied by a separate \$500.00 deposit in the form of a cashier's check, money order, or other bank draft made payable to Edna Township. NO personal checks will be accepted for the assurance deposit. The deposit shall be for the assurance that the access approach will be installed and completed in conformance with the permit, sketches, and other requirements. A period of one (1) year will be allowed for the work to be completed in compliance with all (ings) previously named. If there is failure to complete the work in a satisfactory period of time, the \$500.00 deposit will be forfeited.

Upon completion of the work, receipt of the "Certificate of Completion" by the Town Clerk, and satisfactory final inspection, the \$500.00 deposit shall be returned in its original form. Additional inspections shall be charged the nominal fee of \$50.00 and deducted from the deposit.

Edna Township reserves the right to cause the uncompleted work to be performed, and costs shall be deducted from the deposit with any remainder to be the responsibility of the landowner.

V. INSPECTION

The items that will be inspected upon the request for final inspection are as follows:

1. Proper steel culvert installation
2. Proper fill material and surfacing
3. Proper slope from edge of surface to end of steel culvert as required by pre-inspection.
4. Establishment of seed or sod to prevent erosion
5. Removal of excessive debris, rock, limbs, etc.

As previously stated, if all requirements are not met upon inspection, \$50.00 will be withheld from the initial deposit for each inspection trip made. If necessary, the landowner may be required to pay for additional inspection trips.

VI. UNAUTHORIZED ACCESS APPROACHES

billed assessed Any approach found to be placed adjacent to a Township road, without a valid permit will be *accessed* all permit fees; and subject to inspection by a representative of Edna Township. Should the access approach be found deficient in the required width and elevation, or determined that it will alter drainage in the Township road right-of-way, or placed in such a manner that the sight distance of the oncoming traffic may create a safety hazard, or have been built using substandard or no drainage culvert, the landowner will be required to remove the approach or correct the deficiency at the landowner's expense within the time period of one (1) month from the time of inspection as well as submit the required approach permit fees. Any unauthorized approach found to be deficient and requiring removal will not be allowed to be utilized from the time forward until property corrected. If the landowner does not comply with the requirements stated within this policy the Township Supervisors will cause the approach to be corrected and the landowner will be responsible for the entire cost billed from the Township Clerk.

EDNA TOWNSHIP

Application For Access Approach Permit

Property Owner/Applicant	Site Address
Mailing Address	Phone Number(s)
Is a building to be constructed? () Yes () No	Building will be () Permanent () Temporary
Purpose of Approach () Single Residence () Farm () Commercial, specify () Other, specify	Proposed Location of Approach (specify road, landmark or intersection)
Legal Description of Property	Date Approach is Needed
Location of Present Approach to Property (If Applicable)	Location of Proposed Approach to Property (If Applicable)

I/We the undersigned, herewith make application for permission to construct an access approach at the above location, said location said approach to be constructed to conform with regulations of Edna Township and any special provisions included in the permit. It is agreed that all work will be done to the satisfaction of Edna Township or their representative. It is further agreed that no work in connection with this application will be started until the application is approved and the permit is issued. It is expressly understood that this permit is conditional upon replacement or restoration of the Township Road and its right-of-way to its original or satisfactory condition. It is further understood that this permit is issued subject to compliance with the rules and regulations of any other affected agencies.

_____ Date

_____ Signature of Applicant (Property Owner)

Do Not Write Below This Line

ACCESS APPROACH CONSTRUCTION REQUIREMENTS

1. No work under this application is to be started until application is approved and permit is issued.
2. Where work on a public roadway is necessary, traffic must be protected in accordance with the MMUTCD Field Guide. No Equipment is to be parked on the roadway.
3. No foreign material such as dirt, gravel, or bituminous material shall be left or deposited on the road during the construction of the driveway or installation of drainage facilities.
4. Road surface and road side must be cleaned up after the work is completed and vegetation restored to control erosion.
5. After the approach construction is complete the applicant shall notify the Township Clerk in writing that the work has been completed and is ready for final inspection and approval by submitting the Certificate of Completion found in the approach application package.
6. No changes or alterations will be made to the approach plan or completed approach in the future without the permission of Edna Township.
7. Driveway slopes shall be constructed with ____ :1 slopes (____ feet horizontal drop to each 1 foot of vertical slope) unless otherwise noted, and shall be hand finished and seeded.
8. Driveways shall be constructed to slope down and away from the shoulder line of the Township Road for a distance of at least 15 feet with a fall of at least 6 inches. Applicant will place gravel on the approach surface.

Permission is hereby granted for the construction of the approach as described in the above application, and in accordance with the above requirements. In the event that the construction is not complete by the date stated above, the permit is null and void and the applicant will be subject to the loss of their assurance deposit.

Date

Authorized Agent

Work will be completed by: _____ or Assurance Deposit will be forfeited.

REQUIRED STEEL CULVERT: _____ feet of _____ inch diameter steel culvert
_____ End sections of same diameter as steel culvert
() 4:1 End Sections () 6:1 End Sections () Safety End Sections

CERTIFICATE OF COMPLETION OF APPROACH

EDNA TOWNSHIP

Send or Deliver To:

Edna Town Clerk
P.O. Box 114
Dent, MN 56528

I hereby certify that I have completed the installation of an approach as described in accordance with Edna Township Approach Permit # _____ located on _____ (name of road).

Applicant's Signature

Date

For Office Use Only

The work covered by the above referenced permit number has been satisfactorily completed.

Edna Township

Date

APPROACHES AND ENTRANCES MINIMUM STANDARDS

OTTER TAIL COUNTY HIGHWAY DEPARTMENT

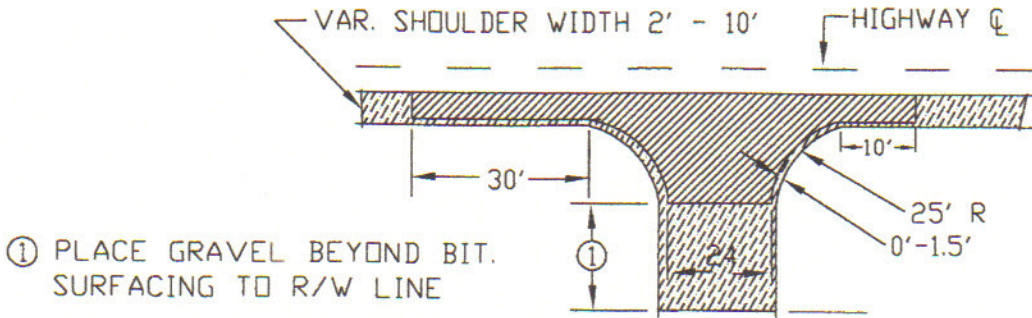

TOP VIEW
(Not to scale)

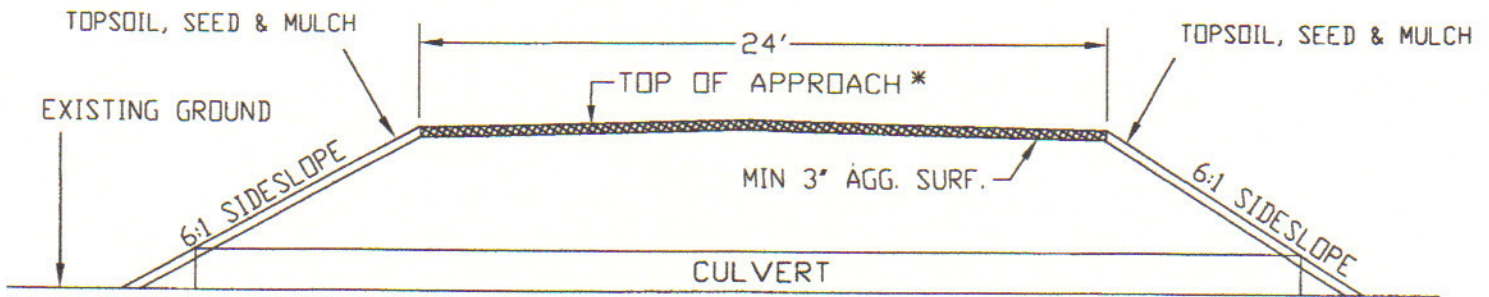

TYPICAL CROSS SECTION OF APPROACH

*A MAXIMUM WIDTH OF 60' MAY BE ALLOWED FOR FIELD APPROACHES WHEN NEED IS JUSTIFIED. APPROACH TOPS WIDER THAN 40' WILL REQUIRE INCREASED PIPE SIZE BY ONE INCREMENT. FOR EXAMPLE A 15" WOULD INCREASE TO AN 18" CULVERT.

